

S5144

2009-2018 RAM 1500, 5.7L V8 HEMI
2019-UP RAM 1500 CLASSIC, 5.7L V8 HEMI,
2009-2013 RAM 1500 4.7L
3" CAT BACK, 2.5" DUAL SPLIT SIDE

MBRP®

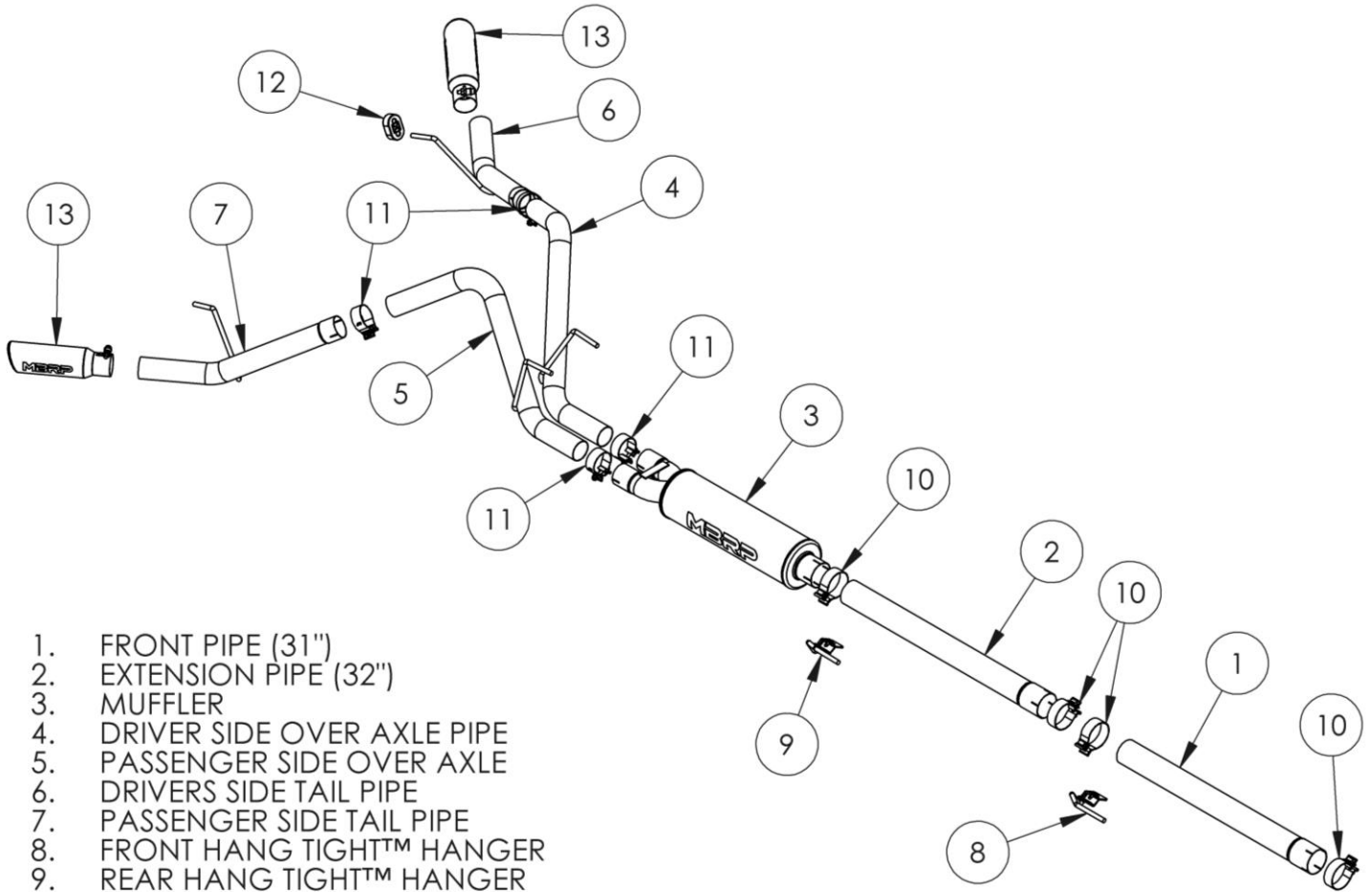

1. FRONT PIPE (31")
2. EXTENSION PIPE (32")
3. MUFFLER
4. DRIVER SIDE OVER AXLE PIPE
5. PASSENGER SIDE OVER AXLE
6. DRIVERS SIDE TAIL PIPE
7. PASSENGER SIDE TAIL PIPE
8. FRONT HANG TIGHT™ HANGER
9. REAR HANG TIGHT™ HANGER
10. 3" CLAMP (4PCS)
11. 2 1/2" CLAMP(4PCS)
12. RUBBER INSULATOR
13. EXHAUST TIP (2PCS)

PLEASE READ BEFORE STARTING INSTALLATION

While MBRP has made every effort to ensure that all components of this system are of superior quality and properly packaged, it is the installer's responsibility to ensure the following before removal of the factory exhaust:

- that ALL components shown above are present.
- that ALL mating components fit together.
- that there are no damaged components.
- that the system you have purchased is appropriate for your vehicle year, model and configuration.
- that the system will not interfere with any modifications previously installed or planned.
- that you have read and understand these instructions.

If you have any questions or are uncertain about any aspect of the installation of this system to your vehicle please contact your dealer before commencing installation.

MBRP



Figure 1



Figure 2



Figure 3



Figure 4

Removal of stock system:

1. Apply a penetrating lubricant liberally to all exhaust fasteners, hangers and rubber insulators.
2. Remove clamp just after the Y pipe. Refer to Figure 1.
3. Remove clamp from the rear of the muffler. Refer to Figure 2.
4. Remove the stock exhaust from the existing hangers and remove the system from the vehicle.

Installation of MBRP Performance Exhaust:

1. Install **Front Pipe** over the existing Y using the **3" Clamp**. The **Front Pipe** will have to be cut depending model. Refer to **Chart 1**. Leave the **3" Clamp** loose enough for adjustment. Refer to **Figure 4**. Note the front pipe will not be required on a regular cab short box.

Cab Type	Box Length	Wheel Base	Front Pipe Required	Cut Required = New Length
Regular	6'4"	120.5	No	N/A
Regular	8'	140.5	Yes	Yes = 23"
Quad Cab	6'4"	140.5	Yes	Yes = 23"
Crew Cab	5'7"	140.5	Yes	Yes = 23"
Crew Cab	6'4"	149.5	Yes	No = 31"

Chart 1

2. Install the **Hang Tight™ Hangers** onto **3.0" Band Clamps** using the procedure shown below. (Hang Tight™ Hanger not exactly as shown)

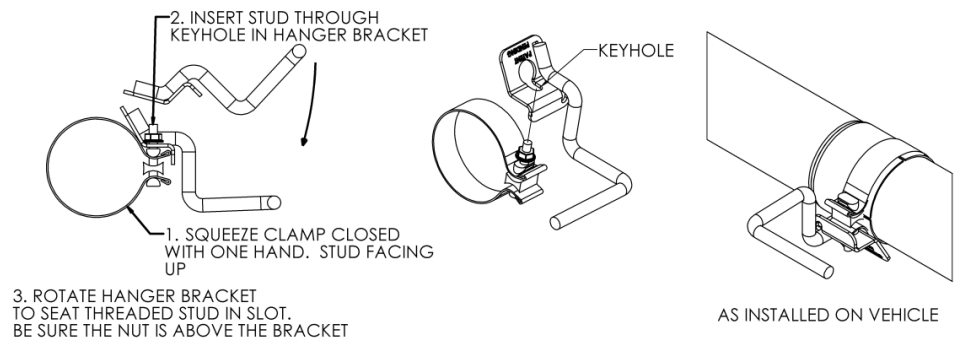

3. Slide the **Front Hang Tight™ Hanger Clamp Assembly** over the **Front Pipe**. Attach the hanger to the existing rubber insulator. Install the **Extension Pipe** to the **Front pipe** using a **3" Clamp**. Refer to **Figure 4**.

MBRP



Figure 5

3. Install the **Rear Hang Tight™ Hanger Clamp Assembly**. Refer to **Figure 5**. Install the **Muffler** to the **Extension Pipe** using the **Hang Tight™ Hanger Clamp Assembly**.

4. Slide two **2 ½” Clamps** over the outlets of the **Muffler**. Position the **Driver Side Over Axle Pipe** over the axle and loosely attach it to the **Muffler**. Install the **Driver Side Over Axle Pipe** hanger into the factory rubber insulator. Repeat these steps for the **Passenger Side Over Axle Pipe**. Refer to **Figure 6 & 7**.



Figure 6

5. Slide a **2 ½” Band Clamp** over the **Driver Side Over Axle Pipe** and install the **Driver Side Tail Pipe**. Insert the **Driver Side Tail Pipe** hanger into the **Rubber Insulator** provided. Refer to **Figure 8**.

6. Slide a **2 ½” Band Clamp** over the **Passenger Side Over Axle Pipe** and then install the **Passenger Side Tail Pipe**. Insert the **Passenger Side Tail Pipe** hanger into the existing rubber insulator.

6. Install and adjust the **Exhaust Tips** to suit. Using a 17mm wrench tighten the lock bolt located on the **Exhaust Tips**. Refer to **Figure 9**.



Figure 7

7. Tighten all hardware and clamps, starting at the front and working rearward to secure the system. Check along the full length of the exhaust system to ensure there is adequate clearance for fuel lines, vent lines, brake lines, frame, bodywork, suspension, and any wiring, etc. If there is any interference detected, relocate, or adjust to provide adequate clearance. Ensure all clamp connections are secure and components are unable to rotate or slide. Band clamps require approximately 45 lb-ft (60 N-m) of torque. Verify clearances, system security and band clamp torque after 30-60 miles (50-100 km) of driving.



Figure 8



Figure 9

Congratulations! You are ready to begin experiencing the improved power, sound and driving experience of your **MBRP** performance exhaust system. We know you will enjoy your purchase.